

ITEM NO.	ITEM NAME
1	Bottom Plate
2	Bottom Plate Bar
3	Side A & B Plate
4	Side A & B Plate Bar
5	Side C & D Plate
6	Top Plate
7	Top Plate Bar
8	Lifting Rod
9	Cover Plate
10	Cover Plate 2
11	Cover For Adjustment
12	Adjustment Cover plate
13	ID Plate
14	Sealing Screw.
15	Screw

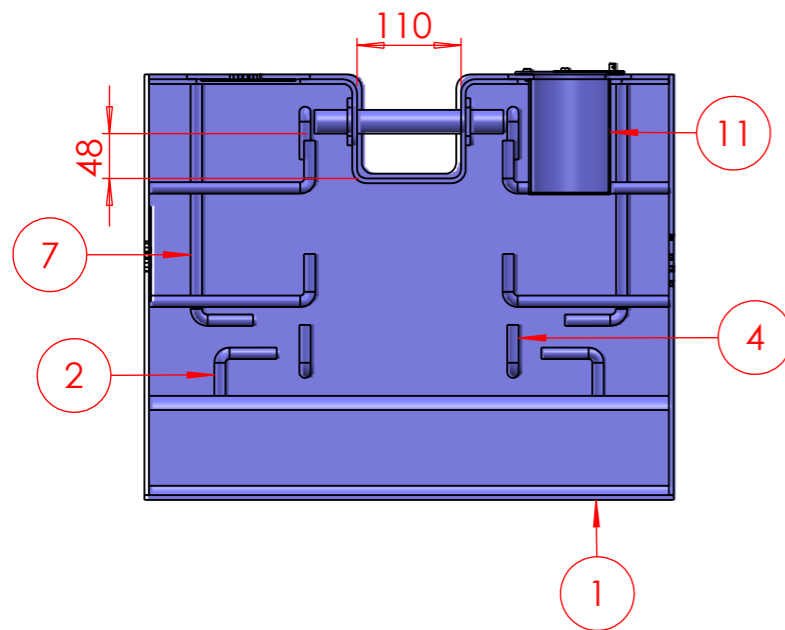

TYPICAL CROSS SECTION

All dimensions are in mm unless specified otherwise.

<b>DISCLAIMER:</b> THIS DRAWING IS A PROPERTY OF E.G. KANTAWALLA PVT.LTD. MODIFICATION OR REPLICATION WITHOUT CONSENT IS AN OFFENCE. THE DRAWING IS SUBJECTED TO CHANGE WITHOUT ANY PRIOR NOTICE.			<b>E. G. KANTAWALLA PVT. LTD.</b> Next to Prakash Memorial School, Upper Kharadi Road, Ubale Nagar, Wagholi, Pune - 412207, Maharashtra. Email : sales@egkantawalla.com					
REFERENCE DRAWING	TITLE		500 kg Weight Block Line Diagram					
	SAP Part No.		RM					
	DWG . NO.		CUST/EGKPL/					
DRAWN BY	NAME	DATE		WEIGH(g)	FORMAT	SCALE	REV	
CHKD. BY	SHW	22.11.2025		2	A3	NTS	00	
APPR. BY	SHW	22.11.2025						