

**SIDE VIEW**

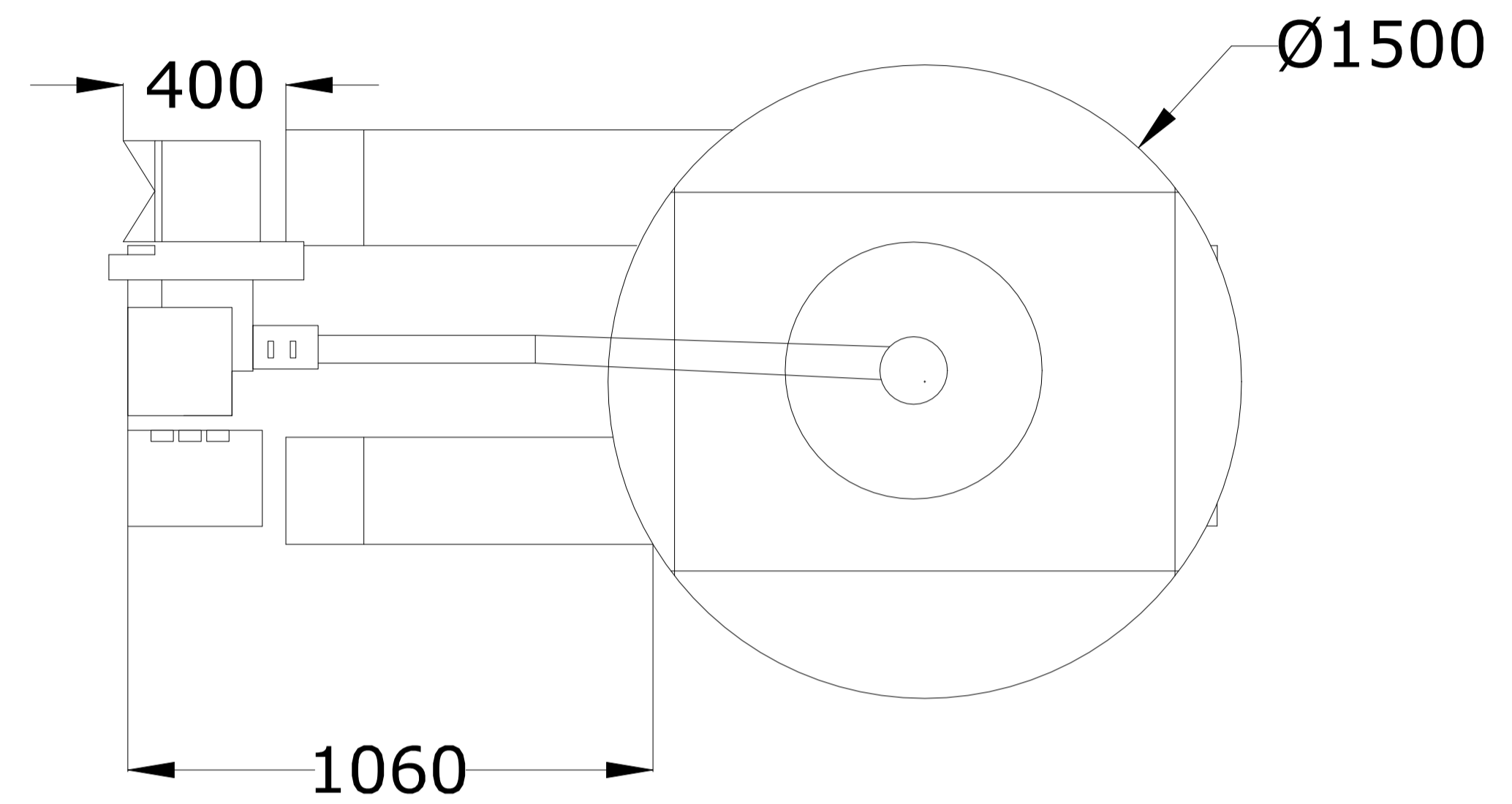

**TOP VIEW**

All dimensions are in mm unless specified otherwise.



**MTL-  
THICKNESS- mm  
S/F TREATMENT -**

REFERENCE DRAWING			TITLE				PALLET WRAPPING MACHINE LINE DIAGRAM						
DRAWN BY			NAME		DATE		DWG . NO.		AMT-20				
CHKD. BY			SHW		04.04.2026				WEIGH(g)		FORMAT	SCALE	REV
APPR. BY			SHW		04.04.2026						A3	NTS	00