

HEAVYDUTY HAND PALLET TRUCK



- ◆ Reliable, sturdy, torsion-resistant due to its extremely strong high quality steel profile.
- ◆ Professional and ideal storage aid for all variety of manual transportation of short distances in stores and warehouse as well as in factories. The lifting system is equipped with overloading protection valve to ensure safe operation.
- ◆ The utilized structural design guarantees the convenience of assembling and disassembling.
- ◆ Compact size, complete rocker arm, ensures that the whole truck is evenly pressed.

◆ **Iron Wheels**



- ◆ Well painted integrated cast hydraulic pump, robust and durable, with fine control of lowering speed, overload valve, and low maintenance rate.



Model		EPT 55070	EPT 68570
Capacity	kg	5000	5000
Pump type		Integrated	Integrated
Wheel(drive/load) Type		IRON	IRON
Size of steering wheel size of loading	mm	200*50	200*50
Wheel(double wheel)	mm	80*75	80*75
Liftng height	mm	110	110
Max. fork lifting height	mm	195	195
Lowered height of fork	mm	85	85
Fork outside distance	mm	550	685
Fork length	mm	1150	1220
Fork width	mm	175	175
weight	kg	121~134	121~134
Fork thickness	mm	5	5

- ◆ Additional entry & exit roller guarantees easy entry and exit of closed pallet.
- ◆ Adjustable push rod can adjust fork to even level when forks are not balanced after long term use or incorret use.
- ◆ 5mm fork steel thickness, robot welding, ensures durability.

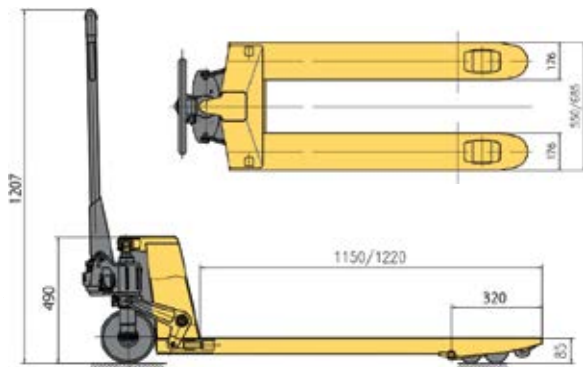

Marketed by:

Accurate Meezan Trading LLC

P.O.Box: 40646, Office # 1909, 19th Floor,
Churchill Tower 1 - Commercial, Business Bay, Dubai - U.A.E
Tel.: +971 4 3337789 / +971 4 3337790 Fax: +971 4 3336210
Email: info.amt@egkantawalla.com



Name & Address of Dealer: