

# Pallet Wrapping Machine



- PLC control+key board control
- Inverter speed control
- Slow start and stop
- Stop at home position
- Auto detect pallet height
- Foldable tower design
- Front and rear forklift access
- Top sheet option
- Variable turntable and film carriage speed
- Middle reinforce
- Can store 5 recipes



Pre-stretch film carriage

## DIMENSIONS

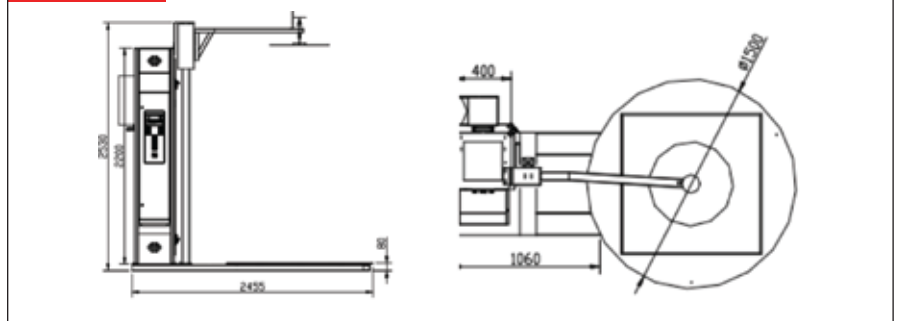

### The Film System -

The open-door film holder makes it more convenient to wear the film. The pre-stretching rate can reach 250%, saving material consumption. Maximize the value of stretched film per meter Standard constant release film Fixed-point winding and quantitative use of film.

### Screen Control -

Parameters can be adjusted from the control panel. Bottom pallet wrapping rounds from 1-10. Top pallet wrapping rounds from 1-10. Rotation speed adjustable from 3 to 10 rpm

### Control System -

PLC control system with more stable operation, heavy duty design with rigid machine body. Soft start and soft stop, safety device. After every wrapping work, turntable goes back to home position.

| SPECIFICATION             |                                   |
|---------------------------|-----------------------------------|
| Model No                  | XT-4505-2                         |
| Description               | Turntable pallet wrapper          |
| Power Supply              | 220V 50HZ 1phase/110V 60hz 1phase |
| Control System            | PLC (Option: touch screen)        |
| Film Carriage             | 250% Pre-stretch film carriage    |
| Turnable Speed            | 1-10 cycles/M                     |
| Max Pallet Height         | 2400mm(Option: 2600/3000mm)       |
| Turntable diameter        | 1500mm (Option: 1650/1800/2000mm) |
| Turntable height          | 80mm                              |
| Turntable motor           | 750W                              |
| Pre-stretch motor         | 180W                              |
| Lifting Motor             | 180W                              |
| Max Pallet Weight         | 1500kg                            |
| Power                     | 1200W                             |
| Machine Weight (NW)       | 435kg                             |
| Machine Dimention (LxWxH) | 2455 x 730 x 2200mm               |

| CONTROL PANEL PARAMETER SETTING |              |
|---------------------------------|--------------|
| Bottom wrapping cycle           | 1-9 cycles   |
| Top wrapping cycle              | 1-9 cycles   |
| Up and down cycle               | 1-9 cycles   |
| Reinforce cycle                 | 1-9 cycles   |
| Photocell delay time            | 1-99 seconds |

| APPLICATION FILM SPECIFICATION |                            |
|--------------------------------|----------------------------|
| Film Type                      | Stretch film machine grade |
| Film Thickness                 | 17-23mic                   |
| Film roll inner diamter        | 76mm                       |
| Film roll outside diameter     | 250mm                      |
| Film width                     | 500mm                      |
| Film roll weight               | 13.8kg                     |

Marketed by:

**Accurate Meezan Trading LLC**

P.O.Box: 40646, Office # 1909, 19th Floor,  
 Churchill Tower 1 - Commercial, Business Bay, Dubai - U.A.E  
 Tel.: +971 4 3337789 / +971 4 3337790 Fax: +971 4 3336210  
 Email: info.amt@egkantawalla.com

Name & Address of Dealer:

