

## ELECTRIC PEDESTRIAN STACKER

# PS12L/PS16L/PS20L PS12DL/PS16DL

Electric Pedestrian Stacker with capacities of 1200/1600/2000kg. PSxxDL series with initial lift available.

### INTRODUCTION

The PS 12–20L series is tailored towards pedestrian controlled stacking operations with capacities from 1200kg up to 2000kg.

With the mounted long tiller the operator can keep a safe and ergonomic distance while performing his work.

Due to the gentle full proportional lift system, stacking operations becomes safer and faster.

With high quality and state of the art top brand components and technology, the truck competes with other leading brands in the market.

- ◆ Safe, Compact and Ergonomic Long Tiller Design.
- ◆ Precise Lifting and Lowering with Fully Proportional Hydraulic System.
- ◆ Powerful, Maintenance Free German AC Power Train.
- ◆ Core Components from Top Quality Brands.
- ◆ 4 Wheel Structure for Stability.



PSL16L

### Long tiller design for ergonomics and safety

With the long tiller design the operator can always keep a safe distance from the truck while working ergonomically.

This design requires less operational forces than trucks with a short tiller. The tiller's operating height is naturally installed to be ergonomic, giving the operator friendly control positions. Stacking operations become quicker and more ergonomic due to safe distancing and a better view of the forks.

The 4 wheel design with the sideways mounted long tiller gives an exact and perfect view to the forks.

### Top brand qualified components

Using high quality core components:

- Reliable multifunctional REMA tiller with ergonomic contactless rocker switches.
- Top quality Schabmueller AC drive motor.
- Kordel gearbox.
- HPI hydraulic power pack.
- Zapi controller.
- Intorque brake.
- Wicke drive wheel.

The parts used reduces high service costs and comes with the performance and reliability which is required for demanding stacking operations.

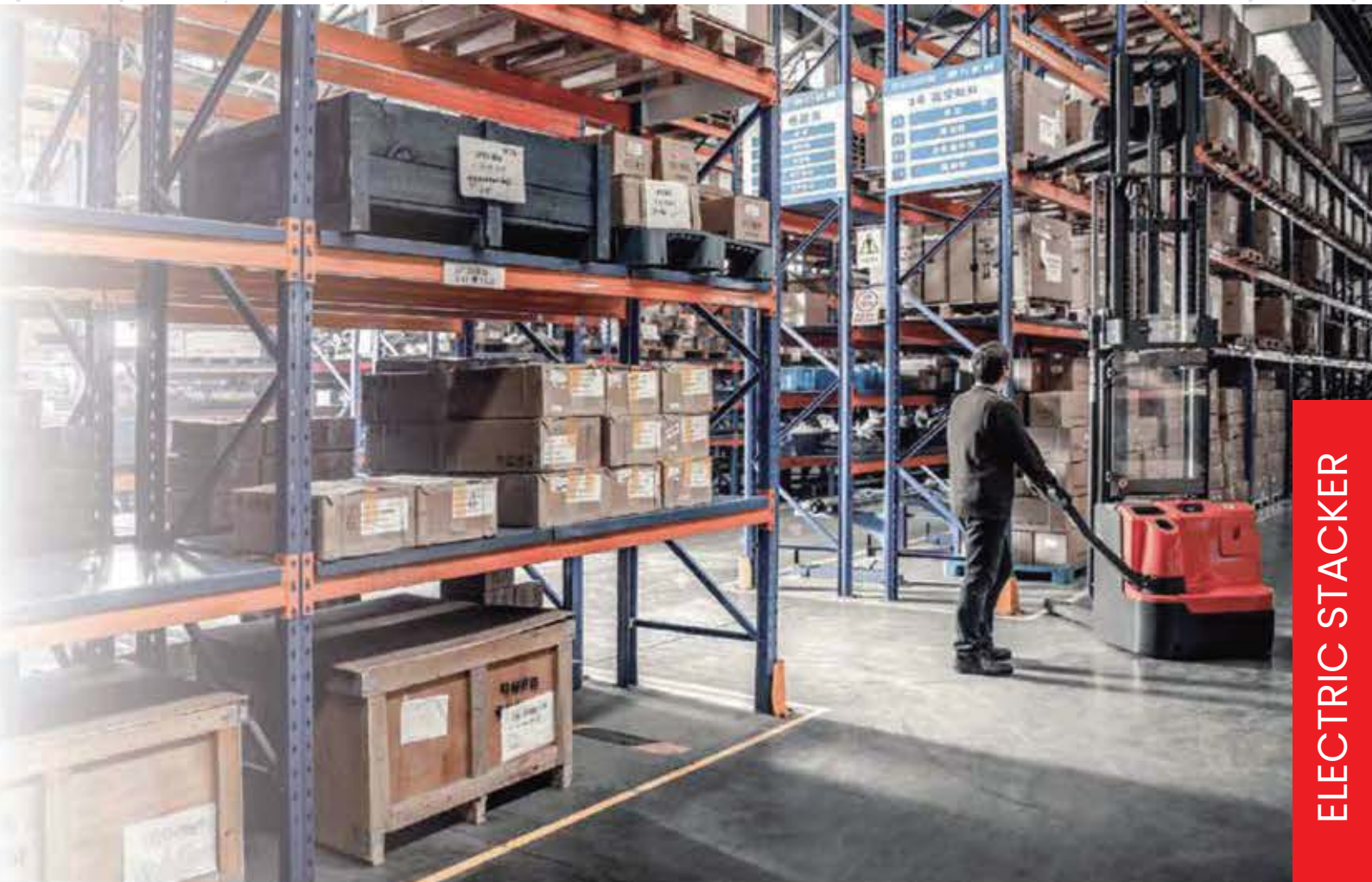

**ELECTRIC STACKER**



Electric proportional lifting and lowering. The electronically controlled proportional lifting system ensures accurate positioning and stacking operations at every lifting height. In specific with high masts the electronic controlled proportional lifting performs at its best.

## **CANBUS**

### **CANBUS Technology**

The CANBUS technology is due to less wiring with more reliability.

For maintenance the CANBUS technology make analyzed and adjustments easier so that the downtime is lower than for trucks without CANBUS.

Digital signals further makes parts longer lasting than analogue signals





### Robust and Reliable Design

- Robust chassis with strong 8 mm thick apron protects truck and components from mechanical impacts.
- Metal battery cover reduces maintenance work and damage.
- Vertical AC motor design is less affected by dirty floor environments; components and brakes are positioned out of reach from direct impacts.
- Controller is IP 54 protected – safe against dust and water splashes.



### German AC Drive Technology

- The powerful maintenance-free German Schabmueller AC Drive motor with German Kordel gearbox, Intorqe brake, and Wicke drive wheel all together gives the best performance, efficiency, and reliability. This top brand combination reduces the overall operating cost!
- Whether smooth or sudden acceleration is required, the AC Drive always gives the right and direct response.



#### Maintenance friendly

The trucks' design and the components used are tailored to make service and maintenance easy. All components are easy to reach after removing the main cover with only two screws.

The drive wheel and the castor wheel are easy to exchange without craning the truck.

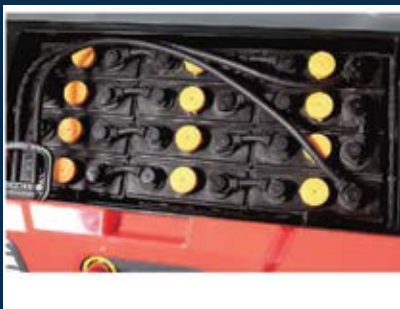

#### For every application the right battery capacity

With the PS-L series every truck comes with the right battery:

- PS 12L with 180 Ah 2VBS battery for light duty models, good maneuverability for restricted areas.
- PS 16L with 270 Ah 3VBS battery
- PS 20L with 350 AH DIN 3PzS battery for long operations and multi- shifts.
- Optional sideway battery exchange compartment for PT20L with 210 Ah battery

#### Optionals

- Various mast versions
- Load backrest
- Sideway battery exchange for PS 16L and PS 20L



PS 20L

**ELECTRIC STACKER**

## Mast table PS12L/PS16L/PS20L

Designation	Lowered mast height h1 mm	Free lift height h2 ( mm)	Lift height h3 mm	Extended mast height h4 mm	Lift+ fork height h3 + h13 mm
<b>PS12L</b>					
Two-stage mast	1958	-	2830	3380	2920
	2108	-	3130	3680	3220
	2308	-	3530	4080	3620
Two-stage mast FFL (Full Free-Lift)	1958	1410	2830	3380	2920
	2108	1560	3130	3680	3220
	2308	1760	3530	4080	3620
Three-stage mast FFL (Full Free Lift)	1998	1320	3930	4480	4020
	2008	1420	4230	4780	4320
	2108	1520	4530	5080	4620
<b>PS16L</b>					
Two-stage mast	1985	-	2830	3380	2920
	2108	-	3130	3680	3220
	2308	-	3530	4080	3620
Two-stage mast FFL (Full Free-Lift)	1958	1410	2830	3380	2920
	2108	1560	3130	3680	3220
	2308	1760	3530	4080	3620
Two-stage mast	2008	-	4230	4780	4320
	2108	-	4530	5080	4620
Three-stage mast	1708	1120	3330	3880	3420
	1908	1320	3930	4480	4020
Three-stage mast FFL (Full Free-Lift)	2008	1420	4230	4780	4320
	2108	1520	4530	5080	4620
	2343	1756	5230	5780	5320
	2408	1820	5430	5980	5520
<b>PS20L</b>					
Two-stage mast	2078	-	2830	3500	2920
	2228	-	3130	3800	3220
	2428	-	3530	4200	3620
Two-stage mast FFL (Full Free-Lift)	1978	1310	2630	3330	2720
	2078	1410	2830	3500	2920
	2228	1560	3130	3800	3220
Three-stage mast	2428	1760	3530	4200	3620
	2128	-	4230	4900	4320
	2228	-	4530	5200	4620
Three-stage mast FFL (Full Free-Lift)	1978	1310	3930	4600	4020
	2128	1420	4230	4900	4320
	2228	1520	4530	5200	4620

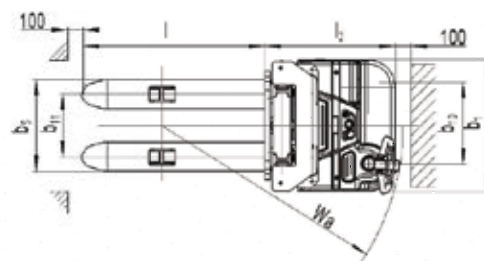
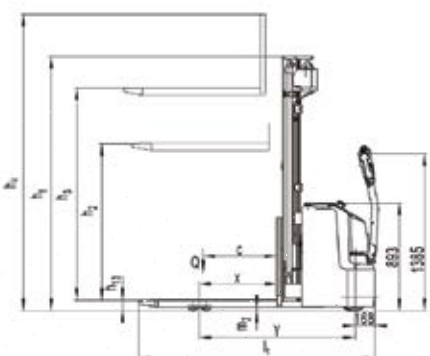

# Type sheet for industrial truck acc. to VDI 2198 tKG=2.2ta tINCH=25.4MM

IDENTIFICATION		PS12L(3600)	PS12L(4600)	PS16L(4600)	PS20L(4600)	
1.2	Manufacturer's type designation	Battery				
1.3	Drive	Pedestrian				
1.4	Operater type					
1.5	Load Capacity / rated load	Q (t)	1.2	1.6	2.0	
1.6	Load centre distance	x (mm)	600			
1.8	Load distance centre of drive axle to fork	y (mm)	647	637	647	
1.9	Wheelbase	y (mm)	1248	1293	1429	
WEIGHTS						
2.1	Service weight	kg	1007	1150	1340	1579
2.2	Axle load at full load, drive side/load side	kg	684/1523	735/1610	930/2010	1000/2579
2.3	Axle load at no load, drive side/load side	kg	610/397	720/430	850/490	900/679
WHEELS, CHASSIS						
3.1	Tires	Polyurethane (PU)				
3.2	Tire, front	Φxw (mm)	Φ230×70			
3.3	Tire, rear	Φxw (mm)	Φ84×70			
3.4	Additional wheels(dimensions)	Φxw (mm)	Φ150x54			
3.5	Wheel number, from front to drive wheels(4 wheels)		1x +1/4			
3.6	Tread, front	b10 (mm)	522			
3.7	Tread, rear	b11 (mm)	390/505			
BASIC DIMENSIONS						
4.2	Lowered mast height	h1(mm)	2308	2108	2108	2228
4.3	Free Lift height	h2(mm)	1760	1520	1520	1520
4.4	Lift	h3(mm)	3530	4530	4530	4530
4.5	Extended maximal height	h4(mm)	4088	5088	5088	5208
4.6	Height of tiller in drive position min/max.	h14(mm)	850/1385			
4.15	Height, lowered	h13(mm)	90			
4.19	Overall length	l1(mm)	1919	1929	1964	2100
4.20	Length to face of forks	l2(mm)	769	779	814	950
4.21	Overall width	b1(mm)	820			
4.22	Fork dimensions	s/e/l (mm)	60/180/1150			
4.23	Width across forks	b5 (mm)	570/685			
4.32	Ground clearance, centre of wheelbase	m2 (mm)	28		28	23
4.33	Aisle width for pallets 1000X1200 crossways	Ast (mm)	2336		2406	2536
4.34	Aisle width for pallets 800X1200 longways	Ast (mm)	2323		2393	2523
4.35	Turning radius	Wa (mm)	1400		1510	1640
PERFORMANCE DATA						
5.1	Travel speed, laden/ unladen	km/h	6.0/6.0		5.7/6.0	5.4/6/0
5.2	Lift speed, laden/ unladen	m/s	0.09/0.14	0.13/0.20	0.13/0.20	
5.3	Lowering speed, laden/ unladen	m/s	0.25/0.20	0.28/0.23	0.28/0.23	
5.8	Max. gradability, laden/ unladen	%	6/12		6/12	6/10
5.10	Service brake		Electromagnetic			
E-MOTOR						
6.1	Drive motor rating S2 60 min	kW	1.3		1.3	1.7
6.2	Lift motor rating at S3 10%	kW	1.5		3.2	3.2
6.3	Battery acc. to DIN 43531/ 36/ 36A, B, C, no		2VBS		3VBS	3PZS
6.4	Battery voltage, nominal capacity K5	V / Ah	24/180		24/270	24/350
6.5	Battery weight	kg	175		230	288
6.6	Energy consumption acc. to VDI cycle	kWh/h	0.95		1.59	1.7
OTHER DETAILS						
8.1	Type of drive control		AC Speed Control			
8.4	Sound level at driver's ear acc. to EN 12053	dB(A)	<70			

Type sleet for industrial truck acc. to VDI 2198 tKG=2.2ta tINCH=25.4MM

Designation	Lowered mast height h1(mm)	Free lift height h2(mm)	Lift height h3(mm)	Extended mast height h4(mm)	Lift + fork height h3+h13(mm)
<b>PS12DL</b>					
Two-stage mast	1958	—	2830	3380	2920
	2108	—	3130	3680	3220
	2308	—	3530	4080	3620
Two-stage mast FFL (Full-Free-Lift)	1958	1410	2830	3380	2920
	2108	1560	3130	3680	3220
	2308	1760	3530	4080	3620
Three-stage mast FFL (Full-Free-FFL)	1998	1320	3930	4480	4020
	2008	1420	4230	4780	4320
	2108	1520	4530	5080	4620
<b>PS16DL</b>					
Two-stage mast	1985	-	2830	3380	2920
	2108	-	3130	3680	3220
	2308	-	3530	4080	3620
Two-stage mast FFL (Full-Free-Lift)	1958	1410	2830	3380	2920
	2108	1560	3130	3680	3220
	2308	1760	3530	4080	3620
Three-stage mast	1408	-	2430	2980	2520
	2008	-	4230	4780	4320
	2108	1756	4530	5080	4620
Two-stage mast FFL (Full-Free-FFL)	1708	1120	3330	3880	3420
	1908	1320	3930	4480	4020
	2008	1420	4230	4780	4320
	2108	1520	4530	5080	4620

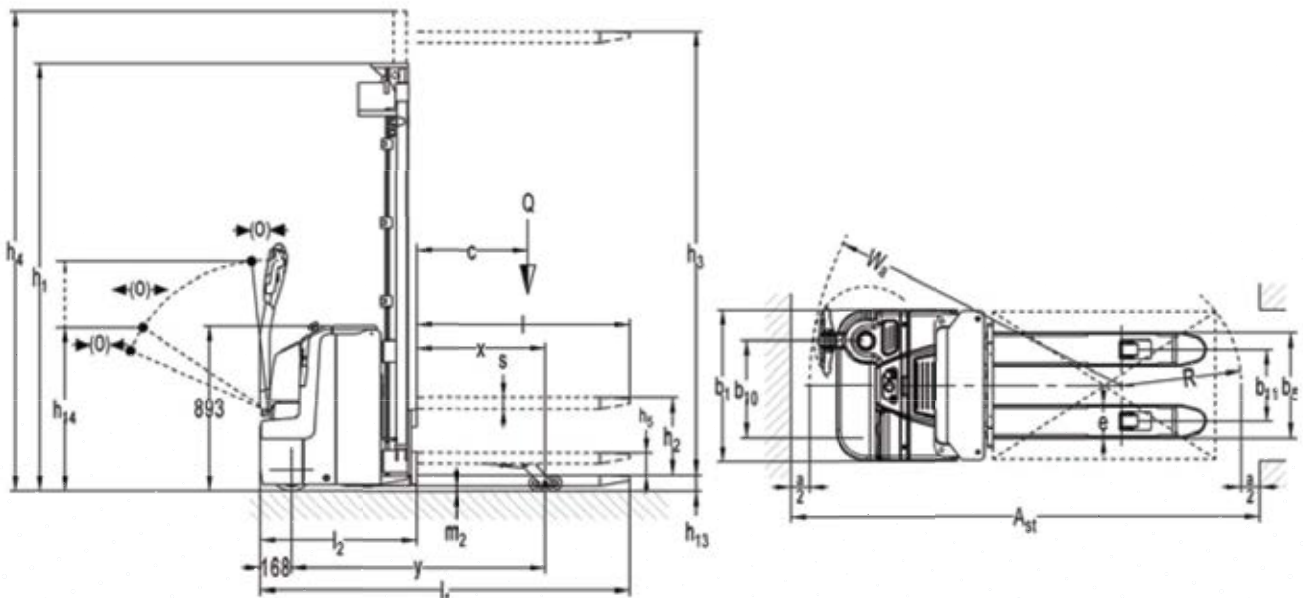

Type sleet for industrial truck acc. to VDI 2198 tKG=2.2ta tINCH=25.4MM

			PS 12DL		PS16DL	
			3600		4600 FFL	
Distinguishing mark	1.2	Manufacturer's type designation				
	1.3	Power (battery ,diesel, petrol, gas, manual)	Battery			
	1.4	Operator type	Pedestrian			
		Load Capacity / rated load	1.2		1.6 <sup>1</sup>	
	1.5	Load capacity at mast lift	1.2		1.6	
		Load capacity at support arm lift	2.0		2.0	
	1.6	Load centre distance	c (mm)	600		
	1.8	Load distance ,centre of drive axle to fork	x (mm)	695		
	1.9	Wheelbase	y (mm)	1374		1417 <sup>2</sup>
Weight	2.1	Service weight	kg	1070		1380
	2.2	Axle loading, laden front/rear	kg	870/2200		1130/2250
	2.3	Axle loading, unladen front/rear	kg	730/340		945/435
Tires, chassis	3.1	Tires		Polyurethane (PU)		
	3.2	Tire size,front	Φxw (mm)	Φ230×70		
	3.3	Tire size,rear	Φxw (mm)	Φ84×70		
	3.4	Additional wheels(dimensions)	Φxw (mm)	Φ150×54		
	3.5	Wheels,number front/rear(x=driven wheels)		1x+1/4		
	3.6	Tread, front	b10 (mm)	522		
	3.7	Tread, rear	b11 (mm)	390/505		
Dimensions	4.2	Lowered mast height	h, (mm)	2308		2108
	4.3	Free Lift height	h <sub>2</sub> (mm)	-		1520
	4.4	Lift height	h <sub>3</sub> (mm)	3530		4530
	4.5	Extended maximal heigt	h <sub>4</sub> (mm)	4080		5080
	4.6	Initial lift	h <sub>5</sub> (mm)	120		
	4.9	Height of tiller in drive position min./ max.	h <sub>6</sub> (mm)	850/1385		
	4.15	Height, lowered	h <sub>7</sub> (mm)	90		
	4.19	Overall length	l <sub>1</sub> (mm)	1998		2042
	4.20	Length to face of forks	l <sub>2</sub> (mm)	848		892
	4.21	Overall width	b <sub>2</sub> (mm)	820		
	4.22	Fork dimensions	s/e/l (mm)	60/180/1150		
	4.25	Distance between fork-arms	b <sub>3</sub> (mm)	570/685		
	4.32	Ground clearance, centre of wheelbase	m <sub>1</sub> (mm)	28		
	4.33	Aisle width for pallets 1000X1200 crossways	Ast (mm)	2540 <sup>2</sup>		2584 <sup>2</sup>
	4.34	Aisle width for pallets 800X1200 lengthways	Ast (mm)	2512 <sup>2</sup>		2555 <sup>2</sup>
4.35	Turning radius	Wa (mm)	1667 <sup>2</sup>		1711 <sup>2</sup>	
Performance data	5.1	Travel speed, laden/ unladen	km/h	5.5/6.0		
	5.2	Lift speed, laden/ unladen	m/s	0.09/0.14		0.13/0.20
	5.3	Lowering speed, laden/ unladen	m/s	0.25/0.20		0.28/0.23
	5.8	Max. gradeability, laden unladen	%	6/12		
	5.10	Service brake		Electromagnetic		
Electric-engine	6.1	Drive motor rating S2 60min	kW	1.7		
	6.2	Lift motor rating at S3 4.5%	kW	1.5		3.2
	6.3	Battery acc. to DIN 43531/35/36 A, B, C, no		2VBS		3VBS
	6.4	Battery voltage, nominal capacity K5	V/Ah	24/180		24/270
	6.5	Battery weight +/-5%	kg	175		230
	6.6	Energy consumption acc: to VDI cycle	kWh/h	1.00		0.96
Additional data	8.1	Type of drive control		AC- speed control		
	8.4	Sound level at driver's ear acc. to EN 12053	dB(A)	<70		

1) when operate the fork and pallet at the same time: Load Capacity/ rated load (mast lift) < Load Capacity/ rated load (support arm lift)

2) Load section lowered: + 72mm



# Power Meets Precision in Every Lift

Marketed by:

**Accurate Meezan Trading LLC**

P.O.Box: 40646, Office # 1909, 19th Floor,  
Churchill Tower 1 - Commercial, Business Bay, Dubai - U.A.E  
Tel.: +971 4 3337789 / +971 4 3337790 Fax: +971 4 3336210  
Email: info.amt@egkantawalla.com

Name & Address of Dealer:

