

# VANGO 500/1000

## Semi Electric Self-lift Stacker

### INTRODUCTION

- AN innovation revolutionizes in the field of load transportation with light commercial vehicles.
- FOR replace your tail-lift, hand pallet truck, stacker, ramp etc.
- EASY and quick transport, can load itself onto your van, pick-up, lorry or trailer (wit or w/o load on forks), increases efficiency and makes the deliveries easier and faster.



# SPECIFICATIONS

		MODEL		VANGO500	VANGO1000
<b>CHARACTERISTICS</b>					
1.1	Capacity	Q	kg	500	1000
1.2	Load center	C	mm	400	400
1.3	Wheel base	L0	mm	815	787
1.4	Front wheel distance	W1	mm	380	398
1.5	Rear Track	W2	mm	665	708
1.6	Operator type			Walkie	Walkie
<b>WHEELS</b>					
2.1	Wheel type			Nylon	Nylon
2.2	Wheel quantity(steering/loading wheels)		pc	2/2	2/4
2.3	Steering wheel size		mm	Φ70×60	Φ70×60
2.4	Loading wheel size		mm	Φ100×45	Φ100×50
2.5	Middle wheel size		mm	Φ40×25	Φ65×30
<b>SPECIFICATION</b>					
3.1	Max. fork height	H	mm	800/1000/1300	1000/1300
3.2	Overall fork width	W3	mm	535	563
3.3	Fork Length	L2	mm	1150	1150
3.4	Fork width*Fork thickness	B2*B	mm	155×60	192.5×60
3.5	Supporting leg length	L1	mm	780	780
3.6	Overall fork length	L3	mm	1570	1544
3.7	Rear body width	W	mm	786	835
3.8	Mast lowered height	H1	mm	1180/1380/1580	1366/1666
3.9	Mast extend height		mm	1940/2140/2390	2120/2476
3.1	Min. turning radius		mm	1100	1100
<b>PERFORMANCE</b>					
4.1	Lifting speed		mm/s	55	82
4.2	Lowering speed		mm/s	70	66
4.3	Lifting motor		kW	DC0.8	DC1.6
<b>BATTERY</b>					
5.1	Battery voltage	V		12	12
5.2	Battery capacity	Ah		45	45
5.3	Battery weight	kg		13.5	13.5
<b>WEIGHT</b>					
6.1	Weight(including battery)	kg		245	290/305

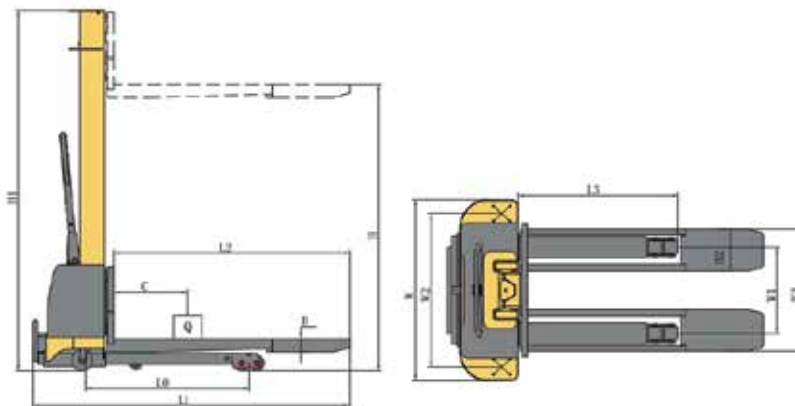

Marketed by:

## Accurate Meezan Trading LLC

P.O.Box: 40646, Office # 1909, 19th Floor,  
Churchill Tower 1 - Commercial, Business Bay, Dubai - U.A.E  
Tel.: +971 4 3337789 / +971 4 3337790 Fax: +971 4 3336210  
Email: info.amt@egkantawalla.com



Name & Address of Dealer: