

ABK / AFK Bench and Floor Scales



Adam's ABK and AFK scales are built tough to deliver reliable performance and effortless weighing. Designed for rugged industrial applications, the sleek, stainless steel indicator with superior sealing protects from dust, ensuring longevity. When used in production and warehouse environments, the large backlit display is vivid and easy to read, helping to streamline activities and reduce errors in data entry. Built-in limit lights make the ABK and AFK ideal for check weighing; the indicator shows when you are below your desired weight, at your required weight, or above your weight, and an audible alarm provides a secondary notification.

No matter what the application, the ABK and AFK offer the right combination of features and performance needed in industry today.

With more than 40 years of experience in the production of weighing instruments, you can trust Adam for quality products that offer a range of features designed for a variety of applications.



ADAM[®]
THE RIGHT BALANCE
Speed, Performance, Value

ABK and AFK Highlights:

Coloured LED indicators make easy work of check-weighing products. Indicators for low, OK and high show users what they need to do, making for faster, more accurate check weighing.

Simple-to-use keypad features colour-coded keys for quick recognition of the most frequently used keys. For example, using the tare key to zero out a container is straightforward, as users can quickly recognize the yellow tare key.

The adjustable indicator can be set to any angle and rotated 360 degrees. The indicator is IP66 rated and can be mounted on the supplied pillar or attached to a wall as needed.

The large backlit display and capacity tracker monitor the weight limits to help protect from overloads. The ABK and AFK offer six weighing units and five weighing modes, including dynamic weighing for measuring moving objects such as liquids or animals, parts counting to perform stock checks, percentage weighing and check weighing.

Durable industrial bench and floor scales

Features

- Six weighing units (kg, g, lb, oz, lb:oz, Newtons)
- Colour-coded keypad
- Display / hold function
- Large backlit display with capacity tracker
- Wall mount or pillar mount indicator, with adjustable viewing angle
- Non-slip rubber feet
- Stainless steel platform
- Stainless steel indicator, sealed for heavy dust and wet environments
- Check-weighing LED indicators
- External automatic calibration
- RS-232 data output
- Rechargeable battery with up to 90 hours of operation on a single charge
- Adjustable auto-sleep/power-down setting to save battery life

Applications

- Weighing
- Parts counting
- Check weighing
- Animal/dynamic weighing
- Percentage weighing

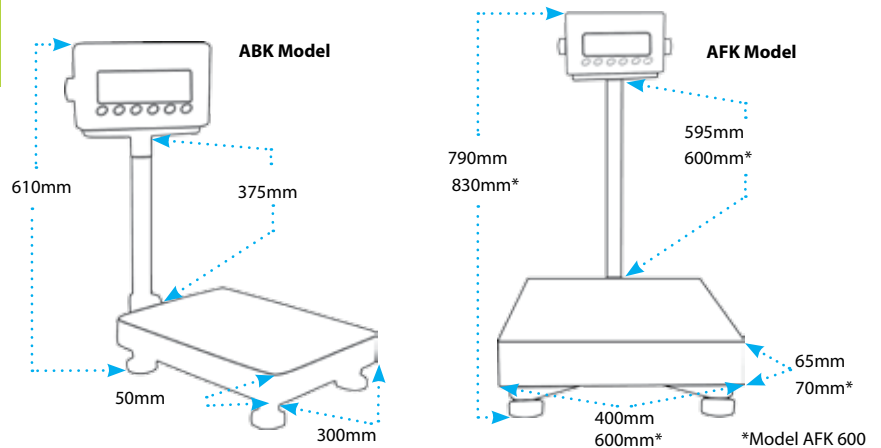

Technical Specifications

Model	ABK 8	ABK 16	ABK 32	ABK 60	ABK 120	AFK 75	AFK 150	AFK 300	AFK 600
Capacity	8000g	16kg	32kg	60kg	120kg	75kg	150kg	300kg	600kg
Readability	0.2g	0.5g	1g	2g	5g	5g	10g	20g	50g
Repeatability (S.D.)	0.2g	0.5g	1g	2g	5g	5g	10g	20g	50g
Linearity (+/-)	0.4g	1g	2g	4g	10g	10g	20g	40g	100g
Pan Size	300 x 400mm					400 x 500mm			600 x 800mm
Weighing Units	g, kg, lb, oz, lb:oz, N								
Stabilization Time	2-3 seconds								
Calibration	External								
Display	Backlit LCD with 40mm digits and capacity tracker								
Power Supply	12vDC 800mA adapter or rechargeable battery (6v 4.5Ah battery)								
Operating Temperature	10° to +40°C								
Construction	Indicator: stainless steel - Top pan: Grade 304 stainless steel pan								
Overall Dimensions (wxdxh)	300 x 520 x 610mm					400 x 620 x 790mm			600 x 940 x 830mm
Net Weight	7.9kg					12.8kg			24.3kg

Accessories

- No. 1120011156 ATP printer
- No. 3123011281 ATP thermal paper (10 pack)
- No. 700000012 Adam printer
- No. 400005055 Adam printer thermal paper (5 pack)

- No. 600002028 AdamDU - data collection program
- No. 1100011297 External relay output box
- No. 700400103 RS-232 cable to PC
- No. 3074010507 RS-232 to USB Interface Cable (must be ordered with 3074010266 RS232 cable)