

Walkie Electric Stacker

PSE10L-C PSE15L-C

- Long-tiller Design
- Capacity 1000-1500Kg
- Easy Maintenance
- CURTIS Technology
- Powerful Battery
- Robust Design
- High Maneuverability
- Best Cost-Performance Ratio

Walkie electric stacker

PSE10L-C/PSE15L-C is an economic walkie electric stacker with rated capacity from 1000kg to 1500kg and lifting height from 1600 to 3600mm, which can meet most customers' requirements for goods stacking. The long-tiller design makes the operator comfortable and safer during operation.



Advantages

- High efficiency and energy saving, long service time.
- High power pump, high lifting efficiency.
- Compact and light design, easy operation.
- High stability, conform with safety standards.
- Strong channel mast provides the stacker with better stability and longer life.
- New appearance design, unified appearance of multiple specifications.

Long tiller design meets the requirements

of ergonomics and safety Long-tiller design ensures the operators' high efficiency and a safe distance from stacker. Compared with the short-tiller stacker, a long-tiller stacker uses less operating force. Besides, the safety distance and good view makes stacking operation more efficient and faster.



Multi-function meter

The multifunction meter displays the vehicle's working status, battery power, and operating time. Proven emergency buttons and electric meters are more durable and reliable than those in other vehicles. The battery discharge indicator features a low-voltage automatic cut-off and lifting function to ensure longer battery service life. The PSEDLC model includes a built-in DCA charger. PSE15L-C has a built-in 15A charger.



PSE10L-C



PSE15L-C

Controller

The PSE15-LC model adopts CAN-bus communication technology, which simplifies the circuitry and enhances overall vehicle reliability. It also uses analog control technology, offering advantages such as intuitive operation, easy diagnostics, and simplified

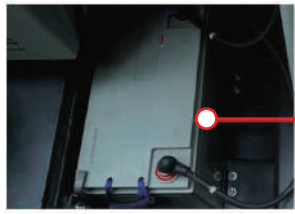

Maintenance-free

lead-acid battery Use maintenance-free lead-acid battery with deep discharge protection. (PSE10L-C 80Ah, PSE15L-C 100Ah)

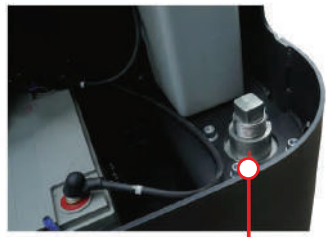

Stability casters

Convenient stability casters adjustment, no need for lifting the stacker.



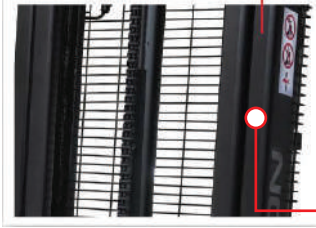

Strong channel steel provides the stacker with better stability and longer life.



Backrest (optional)

Optional high-quality backrest can make the goods more stable and safe when lifting to height.

Debug interface

Lead out the car body through the debugging interface without removing the cover.



PSE10L-C

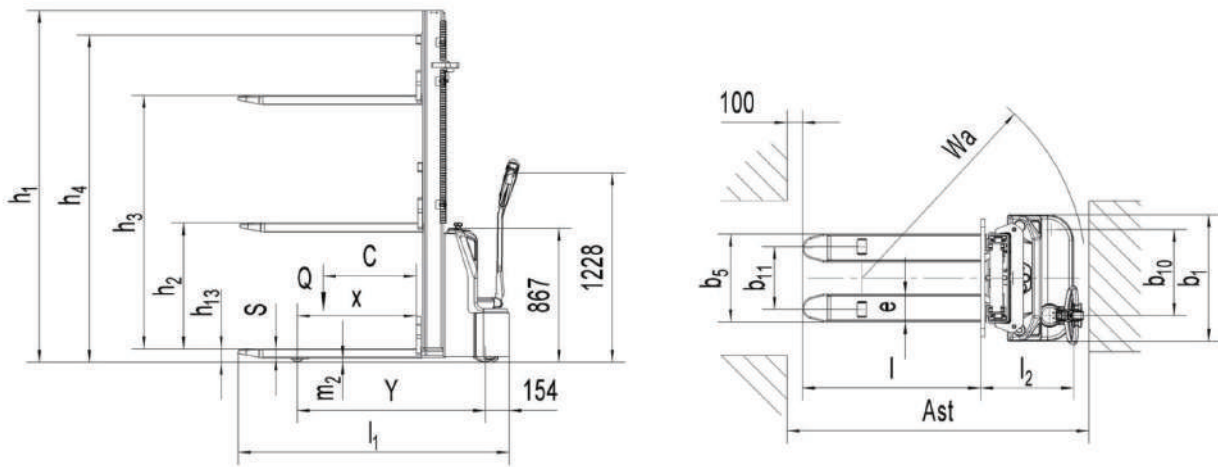

PSE15L-C

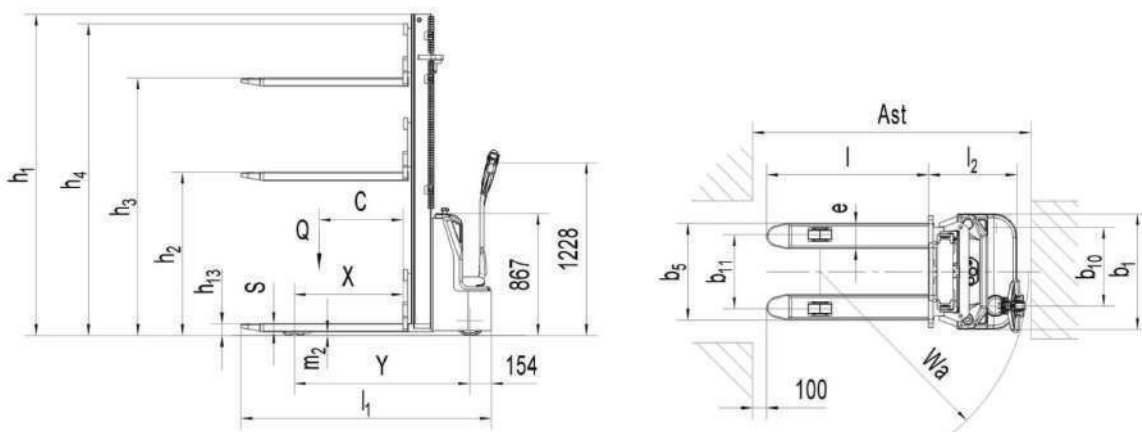

PSL Model (PSE10L-C)

Model	Lowered mast height h1 (mm)	Free lift height h2 (mm)	Lift height h3 (mm)	Extended mast height h4 (mm)	Lift+fork height h3+h13 (mm)
Single mast	2057	1513	1513	2057	1600
	2257	1913	1913	2257	2000
Double mast	1982	-	2813	3389	2900
	2132	-	3113	3689	3200
	2282	-	3413	3989	3500

PSL Model (PSE15L-C)

Model	Lowered mast height h1 (mm)	Free lift height h2 (mm)	Lift height h3 (mm)	Extended mast height h4 (mm)	Lift+fork height h3+h13 (mm)
Single mast	1980	1508	1513	1985	1600
	2380	1908	1913	2385	2000
Double mast	1932	78	2963	3339	2900
	2082	78	3113	3639	3200
	2282	78	3513	4039	3600

Type sheet for industrial truck acc. to VDI 2198

Distinguishing Mark

		PSL Mod (PSE10L-C)		PSL Model (PSE15L-C)	
1.2	Manufacturer's type designation	1600	3500	1600	3600
1.3	Drive	Battery		Battery	
1.4	Operator type	Pedestrian		Pedestrian	
1.5	Load capacity/rated load	1.0		1.5	
1.6	Load center distance	600		600	
1.7	Load distance centre of drive axle to fork	769		779	
1.9	Wheelbase	1215		1220	1245

Weight

2.1	Service weight	kg	450	570	590	750
2.2	Axle loading laden front/rear	kg	490/960	540/1030	640/1450	690/1560
2.3	Axle loading unladen front/rear	kg	130/120	415/155	410/180	525/225

Tyres, Chassis

		Polyurethane (PU)		Polyurethane (PU)	
3.1	Tires	Øxw (mm)		Ø 210x70	
3.2	Tire size front	Øxw (mm)		Ø 80x70	
3.3	Tire size rear	Øxw (mm)		Ø 100x50	
3.4	Additional wheels (dimensions)	1x+1/2		1x+1/2	
3.5	Wheels number (front/rear/driven wheels)	b10 (mm)		557	
3.6	Tread front	b11 (mm)		410/525	
3.7	Tread rear				

Dimensions

4.2	Lowered mast height	h1 (mm)	2057	2282	1980	2282
4.3	Free Lift height	h2 (mm)	1513		1508	78
4.4	Lift	h3 (mm)	1513	3413	1513	3513
4.5	Extended maximal height	h4 (mm)	2057	3989	1985	4039
4.9	Height of tiller in drive position min/max	h14 (mm)	670/1228		670/1228	
4.15	Height lowered	h13 (mm)	87		87	
4.19	Overall length	l1 (mm)	1750		1779	
4.2	Length to face of forks	l2 (mm)	600		629	
4.21	Overall width	b1 (mm)	820		820	
4.22	Fork dimensions	l/s/e/	60/180/1150		60/180/1150	
4.23	Width across forks	b5 (mm)	570/685		570/685	
4.32	Ground clearance centre of wheelbase min/max	m2 (mm)	32		27	
4.33	Aisle width for pallets 1000x1200 lengthwise	As (mm)	2293		2324	
4.34	Aisle width for pallets 800x1200 lengthwise	Ast (mm)	2238		2269	
4.35	Turning radius	Wa (mm)	1450		1481	

Performance data

5.1	Travel speed laden/unladen	km/h	4.0/4.3		4.0/4.4	
5.2	Lift speed laden/unladen	m/s	0.119/0.195		0.087/0.148	
5.3	Lowering speed laden/unladen	m/s	0.166/0.159		0.125/0.117	
5.8	Max. gradeability laden/unladen	%	5/10		5/10	
5.1	Service brake		Electromagnetic		Electromagnetic	

Electric- motor

6.1	Drive motor rating S2 60min	kW	0.75		0.75	
6.2	Lift motor rating at S3 7.5%	kW	2.2		2.2	
6.3	Battery acc. to DIN 43531/35/36 A B C no.		No		No	
6.4	Battery voltage nominal capacity K5	V/Ah	2x12/80		2x12/100	
6.5	Battery weight	kg	2x26		2x34	
6.6	Energy consumption acc. to VDI cycle	kWh/h	0.44		0.68	

Additional data

8.1	Type of drive control		DC- Speed Control		DC- Speed Control	
8.4	Sound level at driver's ear acc. to EN 12053	dB(A)	<70		<70	

Marketed by:

Accurate Meezan Trading LLC

P.O.Box: 40646, Office # 1909, 19th Floor,
Churchill Tower 1 - Commercial, Business Bay, Dubai - U.A.E
Tel.: +971 4 3337789 / +971 4 3337790 Fax: +971 4 3336210
Email: info.amt@egkantawalla.com



Name & Address of Dealer: