

FE4P16-20Q



4-Wheel Electric Forklift 1600-2000Kg capacity

Key Features

Excellent ergonomic design

Powerful battery

Easy maintenance

Robust design

High performance

Product Overview

The arrival of the Q series constitutes the new layout of medium duty products. It is developed on the original basis of the products and combined with the advantages of similar products. It is a cost-effective product with high quality and reliability. The Q series is suitable for medium duty working conditions and meets the needs of most customers.

AC MAINTENANCE-FREE DRIVE MOTOR

Adopt maintenance-free and powerful AC drive motor. Compared with traditional DC motors. AC motors do not need to replace Carbon brushes. Equipped With speed sensor and temperature sensor. greatly improving the AC motor's reliability.

LOW NOISE, LOW VIBRATION DESIGN

The hydraulic system uses a low-noise gear pump and full hydraulic power steering. Low noise and comfort-able operation. Steering axle vibration absorb design: adopts flexible connection to protect the vehicle system and prolong the service life of the forklift

SIDE- EXTRACTION BATTERY

Battery can be replaced easily by using another forklift, meeting continuous application if necessary.

SAFER AND EASIER ELECTROMAGNETIC BRAKE

Adopts car control mode and electromagnetic braking to make the driver's operation more comfortable.

LOW CENTER OF GRAVITY

Transmission system uses a horizontal fan-shaped drive Axle arranged in parallel and has a large transmission ratio. The battery is installed at the bottom of the frame, vehicle height is 2080mm with easy entrance to limited doors and high stability.



Q series Medium Duty Design



The forklift is equipped with standard LED lamps: headlamps, front turn lamps, rear combination lamps, warning lamps. Bright light with low power consumption allows you to operate freely at night.

The vehicle hood and the left and right small side-panels are formed by steel plates at one time, which is simple and decent and more convenient to operate.



Intelligent buffering when descending to the ground, effectively protecting the ground and cargo from damage.

Compared with other N series 4-wheel Electric counter balance forklift, this model is smaller in size and more flexible, which is more suitable for working in confined areas.



Product Features

Transmission system uses a horizontal fan-shaped drive axle arranged in parallel with a large transmission ratio. The battery is installed at the bottom of the frame. Traveling motor adopts AC maintenance-free motor.



Steering axle vibration absorb design: adopt flexible connection to protect the vehicle system and prolong the service life of the forklift.



Adopt car control mode: Suspended driving brake system, stepless speed change. Finding driving pleasure at work.



Front multi-way valve operating device makes operation more comfortable.



Multi-function display screen with fault alarm, low battery reminder. High, medium and low speed modes.



Electromagnetic brake button cut off power at one time. making brake safer and easier.



Ergonomics design for comfort operation with wide mast view and easy right-sided control levers and easy steering wheel with knob.

The trucks are equipped with Curtis controllers, CAN-bus technology makes the diagnostic and troubleshooting easier. The use of proved and certified components helps to ensure the conformity to international safety standards with all the supporting documents available as required by law.

Battery Status		Warning								
Battery Num	16	Single Volt Over	Normal	Charge Electric Over	Normal					
Battery Type	Lithium	Total Volt Over	Normal	Discharge Electric Over	Normal					
Voltage(V)	52.4Electric(A)	Single Volt Lack	Normal	Electric Over Badly	Normal					
Electric(A)	0.0	Total Volt Lack	Normal	SOC Lack	Normal					
SOC	63.9%	Discharge Temp High	Normal	Gathering Line Off	Normal					
Discharge	ON	Discharge Temp Low	Normal	Diff Volt Over	Normal					
Mean Volt(mV)	3281	Charge Temp High	Normal	Envi Temp High	Normal					
Diff Volt(mV)	2	Charge Temp Low	Normal	Envi Temp Low	Normal					
Mean Temp(°c)	11.1									
Diff Temp(°c)	0.7	Single Temp	1	2	3	4	5	6	7	8
Envi Temp(°c)	10.9	01-08	11.3°c	11.0°c	11.1°c	11.7°c	11.2°c	11.0°c	11.5°c	11.6°c
Charge	OFF	09-16	11.1°c	11.3°c	11.1°c	11.7°c	11.1°c	11.2°c	11.6°c	11.7°c
BMS Time	2020-12-12 10:36:14									
Max Volt No.(mV)	[1] 3281	Single Volt	1	2	3	4	5	6	7	8
Min Volt No.(mV)	[5] 3280	01-08	3.281V	3.282V	3.281V	3.281V	3.281V	3.281V	3.282V	3.280V
Max Temp No.(°c)	[4] 11.7	09-16	3.282V	3.281V	3.281V	3.281V	3.281V	3.282V	3.282V	3.280V
Min Temp No.(°c)	[2] 11.0									

It is optional to equip the forklift with Lithium battery with the advantage of maintenance-free and fast charging, no headaches for end users esp. light-duty/occasional applications.

Lead-acid and lithium batteries are perfectly interchangeable. Don't worry about which battery to choose now.



Each battery can be diagnosed via CAN connection with help of special software tool, the software can provide information about the battery condition such as balance of cells, amount of charging/discharging cycles, current, energy consumption, temperature, charging/discharging parameters, voltage of every cell, faults and alarms, settings of timing for automatic turn off.



Designation	Lift height h3(mm)	Free Lift h2(mm)	Closed mast height h1(mm)	Extended mast height h4(mm)	Tilt forward/ backward $\alpha/\beta(^{\circ})$	Capacity table(kg) C=500mm without sideshift single tyres	
						FE4P16Q	FE4P20Q
Two-stage ZT	2500	110	1803	3482	6/10	1600	2000
	2700	110	1903	3682	6/10	1600	2000
	3000	110	2053	3982	6/10	1600	2000
	3300	110	2203	4282	6/10	1600	2000
	3500	110	2303	4482	6/10	1600	2000
	3700	110	2403	4682	6/10	1600	1900
	4000	110	2603	4982	6/6	1500	1800
	4300	110	2753	5282	6/6	1400	1600
	4500	110	2853	5482	6/6	1350	1500
	5000	110	3128	5982	6/6	900	1100
	2500	853	1803	3482	6/10	1600	2000
	2700	953	1903	3682	6/10	1600	2000
	3000	1103	2053	3982	6/10	1600	2000
Two-stage ZZ	3300	1253	2203	4282	6/10	1600	2000
	3500	1353	2303	4482	6/10	1600	2000
	3700	1453	2403	4682	6/10	1600	1900
	4000	1653	2603	4982	6/6	1500	1800
	4000	1029	1978	4981	6/6	1500	1800
	4300	1153	2103	5330	6/6	1400	1600
Three-stage DZ	4500	1203	2153	5480	6/6	1300	1500
	4800	1303	2253	5780	6/6	1000	1200
	5000	1403	2353	5980	6/6	900	1100

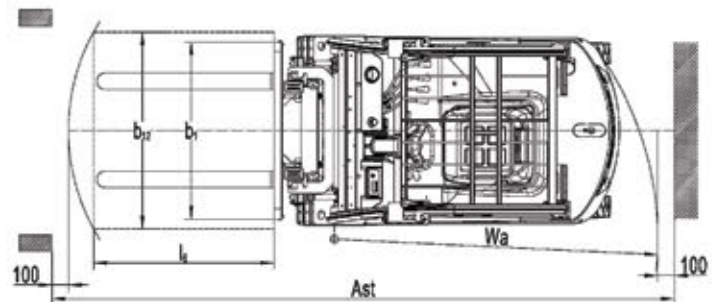
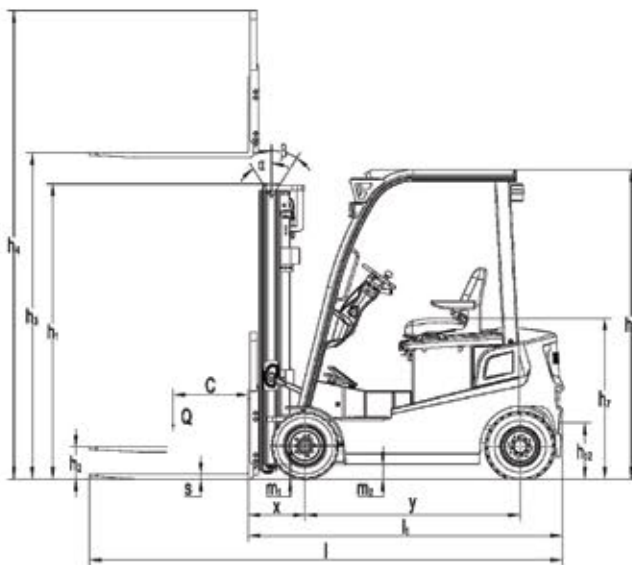

FE4P16-20Q

DISTINGUISHING MARK

1.2	Manufacturer's type designation		FE4P16Q	FE4P20Q
1.3	Drive:electric(battery or mains) diesel petrol gas manual		Electric	Electric
1.4	Type of operation(hand pedestrian standing seated order-picker)		Seated	Seated
1.5	Load capacity/rated load		1600	2000
1.6	Load centre distance	Q(kg) C(mm)		500
1.8	Load distance centre of drive axle to fork	x(mm)	381	386

WEIGHT

2.1	Service weight incl battery	kg	2940	3180
-----	-----------------------------	----	------	------

WHEELS CHASSIS

3.1	Type:solid rubber superelastic pneumatic polyurethane		solid rubber/pneumatic	
3.2	Tyres size front		18X7-8	
3.3	Tyres size rear		5.00-8-10PR	
3.5	Wheels number front rear (x=driven wheels)		2x/2	
3.6	Track width front	b10(mm)	980	
3.7	Track width rear	b11(mm)	920	

DIMENSIONS

4.1	Mast fork carriage tilt forward backward	α/β (°)	6/10	
4.2	lowered mast height	h1(mm)	1985	
4.3	Free lift	h2(mm)	130	
4.4	Lift height	h3(mm)	3000	
4.5	Extended mast height	h4(mm)	3990	
4.7	Overhead load guard height	h6(mm)	2075	
4.8	Seat height standing height	h7(mm)	1065	
4.12	Coupling height	h10(mm)	530	
4.19	Overall length	l1(mm)	3050	3200
4.2	Length to face of forks	l2(mm)	2130	
4.21	Overall width	b1(mm)	1150	
4.22	Fork dimensions	s/e/l(mm)	35/100/920	40/120/1070
4.24	Fork carriage width	b3(mm)	1040	
4.31	Ground clearance laden under mast	m1(mm)	98	
4.32	Ground clearance centre of wheelbase	m2(mm)	100	
4.33	Aisle width for pallets 1000x1200 crossways	Ast(mm)	3571	3576
4.34	Aisle width for pallets 800x1200 lengthways	Ast(mm)	3771	3776
4.35	Turning radius	Wa(mm)	1990	

PERFORMANCE DATA

5.1	Travel speed laden/unladen	km/h	12/13	11/13
5.2	Lift speed laden/unladen	m/s	0.27/0.35	0.25/0.35
5.3	lowering speed laden/ unladen	m/s	0.52/0.42	
5.7	Max Gradient performance laden/unladen \$2 5 min	%	12/15	
5.8	Service brake		electromagnetic brake	

E-MOTOR

6.1	Drive motor rating S2 60 min	kW	7	
6.2	Lift motor rating at S3 15%	kW	8.6	
6.3	Battery standard		DIN	
6.4	Battery voltage nominal capacity K5	V/Ah	Pb-acid:48/360(48/400 48/460) Li:48/200(48/300 48/400)	Pb-acid:48/400(48/460) Li:48/200(48/300 48/400)

OTHER DETAILS

8.1	Type of drive control		AC	
8.2	Operating pressure for attachments	Mpa	14.5	
8.3	Oil volume for attachments	l/min	30	
8.4	Sound level at driver's ear according to EN 12053	dB(A)	72	

Marketed by:

Accurate Meezan Trading LLC

P.O.Box: 40646, Office # 1909, 19th Floor,
Churchill Tower 1 - Commercial, Business Bay, Dubai - U.A.E
Tel.: +971 4 3337789 / +971 4 3337790 Fax: +971 4 3336210
Email: info.amt@egkantawalla.com

Name & Address of Dealer:

